

E-TRACK Fixed Track

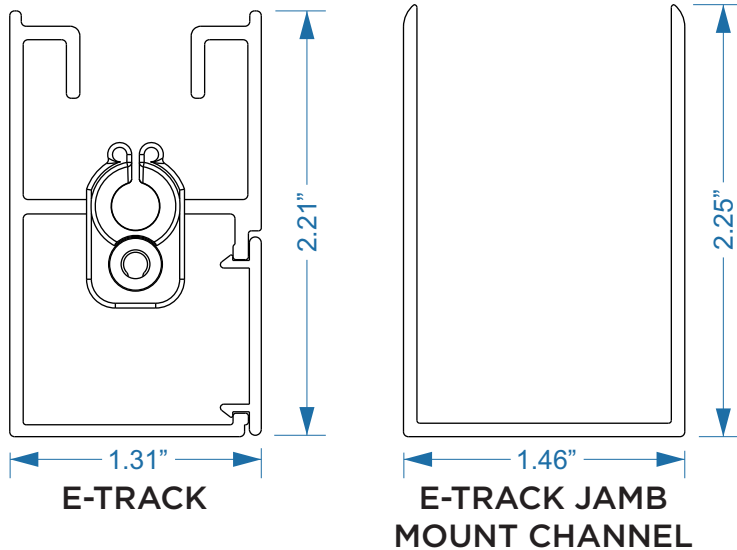

SEE CHARTS FOR:

- A) Track Type and Screen Compatibility
- B) Track and Hood Compatibility
- C) Hoods, Motors and Screen Sizes
- D) Standard Extrusion Colors

Please consult HOW TO MEASURE section for details on measuring screens for production orders.

MOUNTING HARDWARE NOT PROVIDED

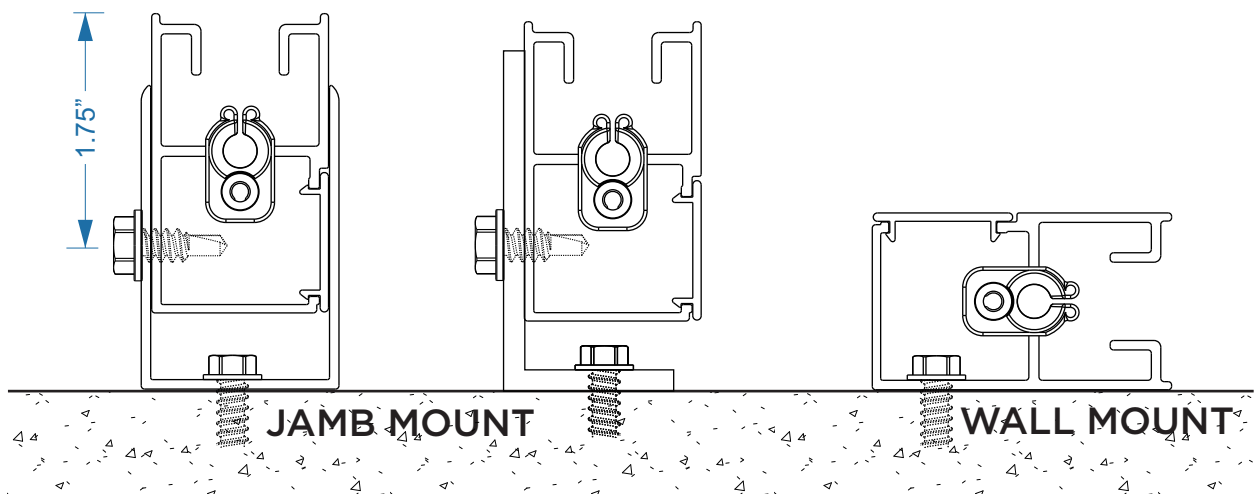

The preferred method for Jamb mount installations uses color coordinating E-Track Jamb Mount Channel. Alternatively, angle can be used (color matching angle may not be available or available with powder coating at additional cost), both simplify installations when columns are uneven or out of plumb. Fasten Jamb Channel or angle with 1/4" Tapcons or construction lag screws with at least 1.5" embedment in concrete or wood at 24" spacing or #10 s/s hex head TEK screws into metal at 18" spacing. Double fasteners where wind-speeds are likely to exceed 50MPH. Fasten E-Track to Jamb Channel or angle with #10x1/2" TEK screws or 3/16" aluminum rivets on 36" spacing and on both sides of Jamb Channel where winds will likely exceed 50MPH.

ONE-TRACK Self-Adjusting

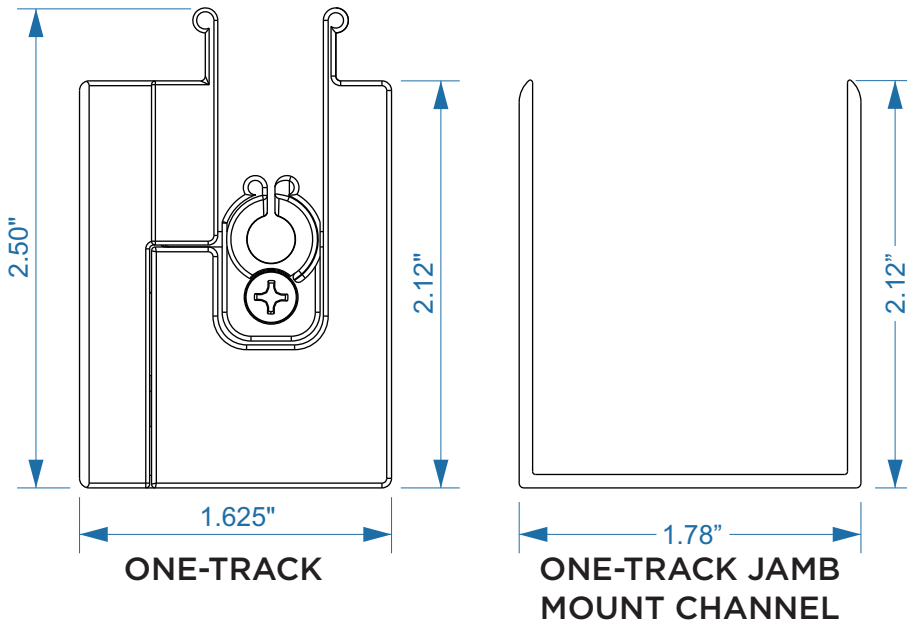

SEE CHARTS FOR:

- A) Track Type and Screen Compatibility
- B) Track and Hood Compatibility
- C) Hoods, Motors and Screen Sizes
- D) Standard Extrusion Colors

Please consult **HOW TO MEASURE** section for details on measuring screens for production orders.

MOUNTING HARDWARE NOT PROVIDED

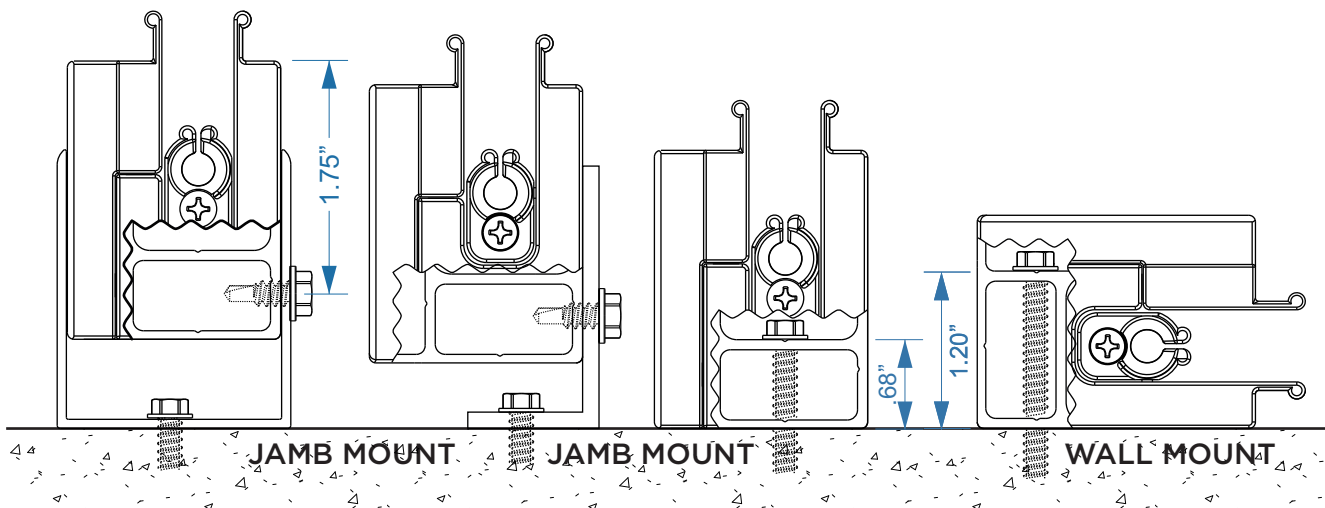

The preferred method for Jamb mount installations uses color coordinating ONE-Track Jamb Mount Channel. Alternatively, angle can be used (color matching angle may not be available or available with powder coating at additional cost), both simplify installations when columns are uneven or out of plumb. If columns are plumb and true, One-Track can be fastened directly to substrate. Fasten Jamb Channel or angle with 1/4" Tapcons or construction lag screws with at least 1.5" embedment in concrete or wood at 24" spacing or #10 s/s hex head TEK screws into metal at 18" spacing. Double fasteners where wind-speeds are likely to exceed 50MPH. Fasten E-Track to Jamb Channel or angle with #10x1/2" TEK screws or 3/16" aluminum rivets on 36" spacing and on both sides of Jamb Channel where winds will likely exceed 50MPH.

ONE-TRACK BUILT-IN CHANNEL

SEE CHARTS FOR:

- A) Track Type and Screen Compatibility
- B) Track and Hood Compatibility
- C) Hoods, Motors and Screen Sizes
- D) Standard Extrusion Colors

Please consult HOW TO MEASURE section for details on measuring screens for production orders.

MOUNTING HARDWARE NOT PROVIDED

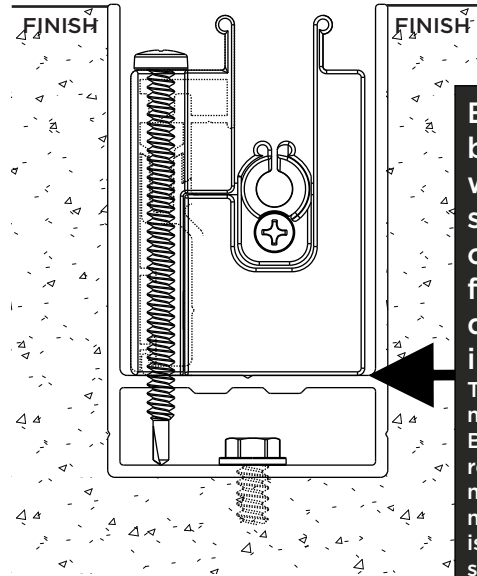
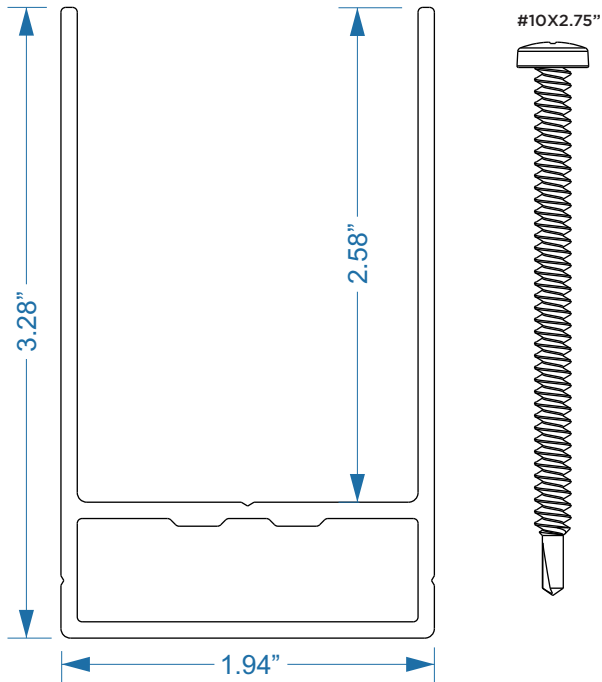

Back of One-Track bracket must align with the mounting surface of Built-In channel for proper fit of the reel during screen installation.

The reason is that the mounting surface of the Built-In channel is replacing a jamb style mount. In a jamb style mount the bracket or hood is always mounted on the same plane as the outside edge of the One-Track, see Installation Instructions for more details.

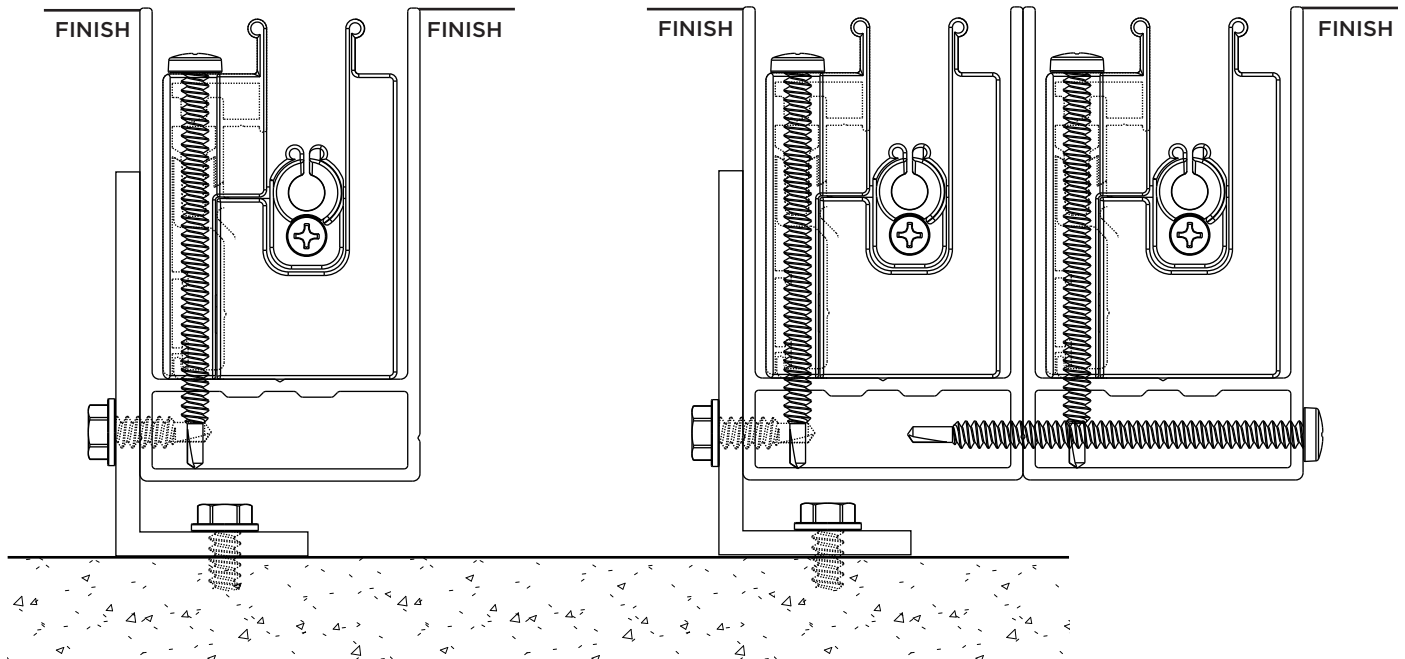

ONE-TRACK BUILT-IN BRACKETS

Fasten brackets with (4) 1/4" Tapcons or #10 s/s hex head and select length for 2" embedment to substrate.

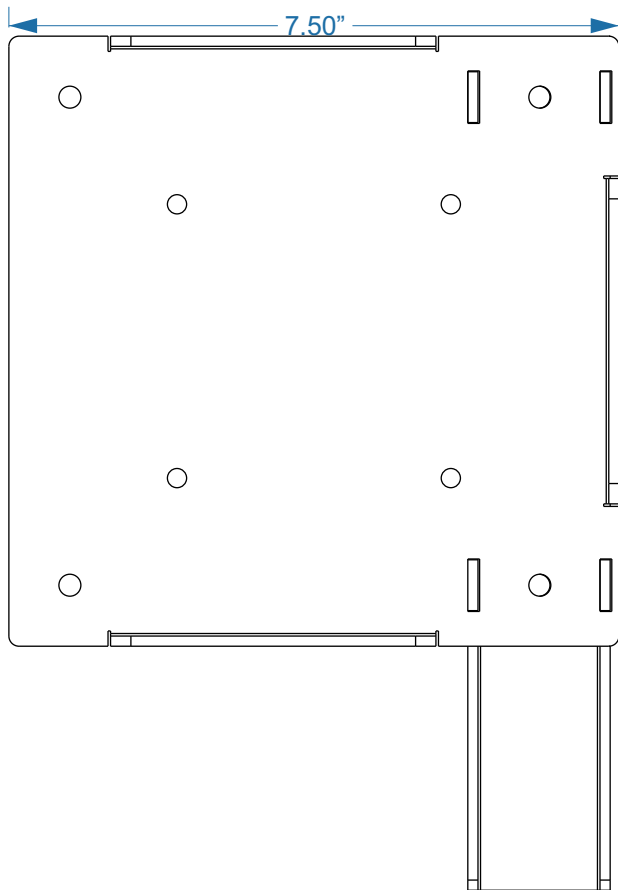
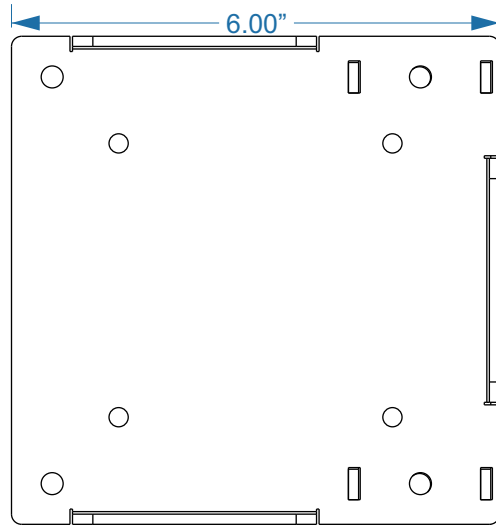

SEE CHARTS FOR:

- A) Track Type and Screen Compatibility
- B) Track and Hood Compatibility
- C) Hoods, Motors and Screen Sizes

Please consult HOW TO MEASURE section for details on measuring screens for production orders.

MOUNTING HARDWARE NOT PROVIDED

Multiple brackets may be used for dual screen installations.

Leg of One-Track bracket slides into Built-In channel for proper fit of the reel during screen installation.

Once the channel is mounted, the bracket can be raised or lowered to establish level. Once level is achieved, fasten the bracket leg to channel and secure the remaining bracket to substrate fasteners. The leg can be removed if it is not needed.

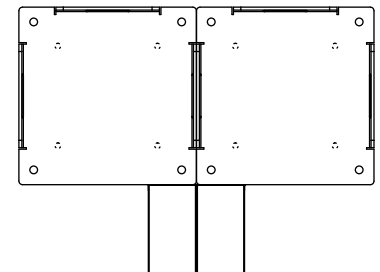
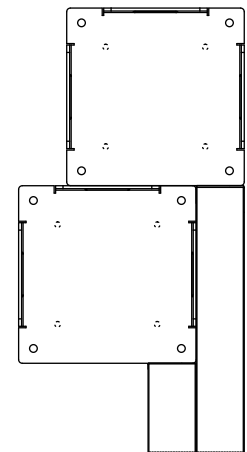

MAXFORCE (HURRICANE TRACK)

See PRODUCT APPROVAL FL8637 for Installation Details

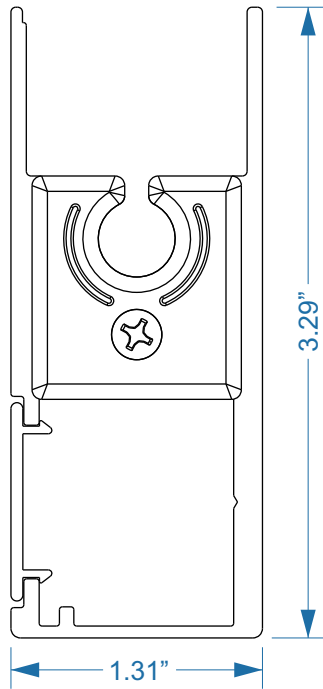

SEE CHARTS FOR:

- A) Track Type and Screen Compatibility
- B) Track and Hood Compatibility
- C) Hoods, Motors and Screen Sizes
- D) Standard Extrusion Colors

Please consult HOW TO MEASURE section for details on measuring screens for production orders.

MOUNTING HARDWARE NOT PROVIDED

Scan for FL8637

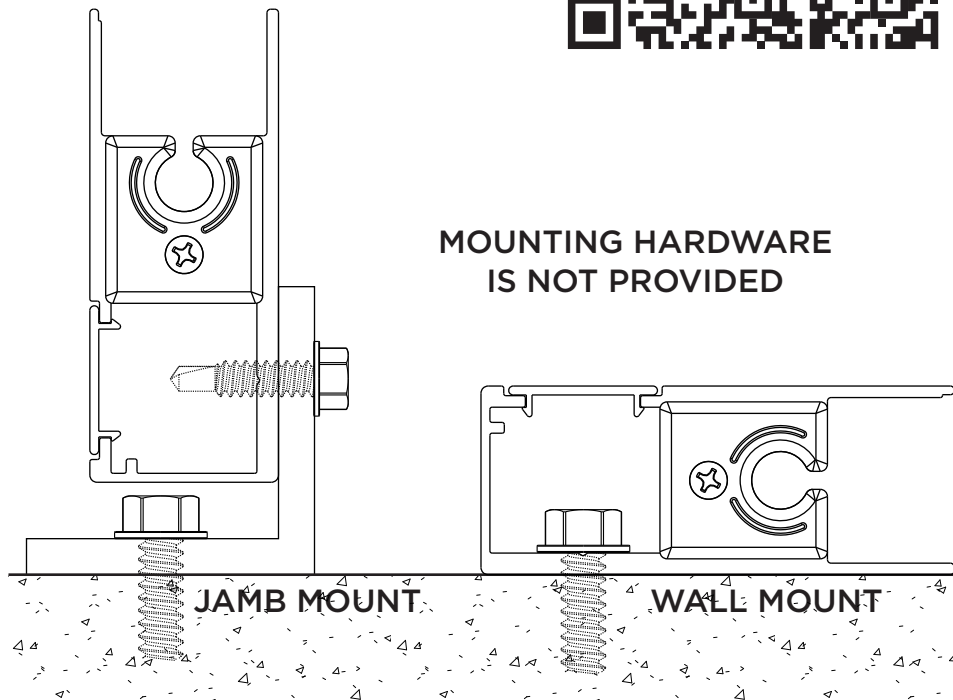

MOUNTING HARDWARE IS NOT PROVIDED

Jamb mount installations are achieved with an angle which will also simplify installations for columns that are uneven or out of plumb. See Florida Product Approval FL8637 for fastening details and build out options.

4.75" HOOD

SEE CHARTS FOR:

- A) Track Type and Screen Compatibility
- B) Track and Hood Compatibility
- C) Hoods, Motors and Screen Sizes
- D) Standard Extrusion Colors

Please consult **HOW TO MEASURE** section for details on measuring screens for production orders.

MOUNTING HARDWARE NOT PROVIDED

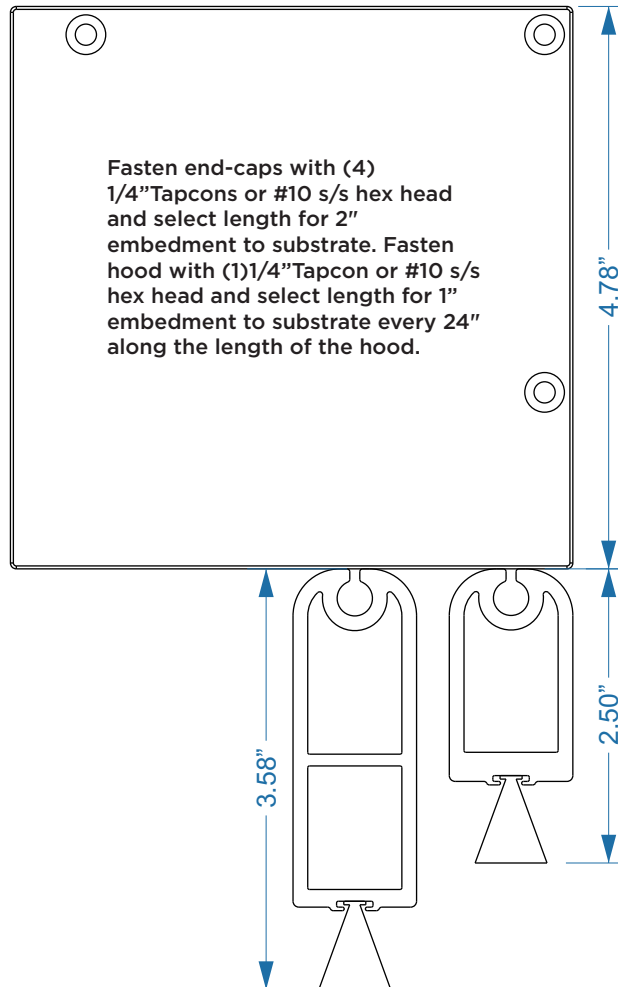

5.5" HOOD

SEE CHARTS FOR:

- A) Track Type and Screen Compatibility
- B) Track and Hood Compatibility
- C) Hoods, Motors and Screen Sizes
- D) Standard Extrusion Colors

Please consult **HOW TO MEASURE** section for details on measuring screens for production orders.

MOUNTING HARDWARE NOT PROVIDED

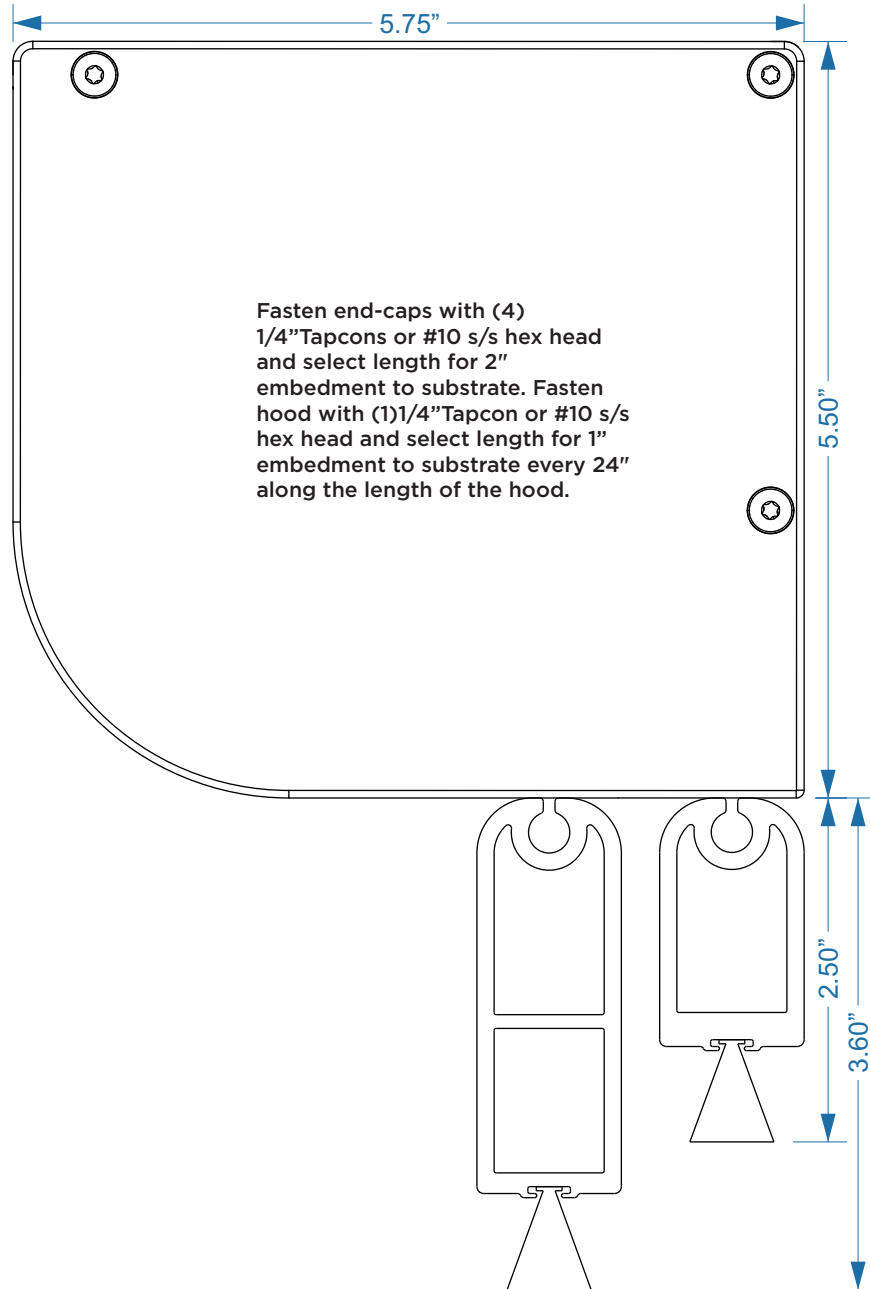

7.0" HOOD

SEE CHARTS FOR:

- A) Track Type and Screen Compatibility**
- B) Track and Hood Compatibility**
- C) Hoods, Motors and Screen Sizes**
- D) Standard Extrusion Colors**

Please consult HOW TO MEASURE section for details on measuring screens for production orders.

MOUNTING HARDWARE NOT PROVIDED

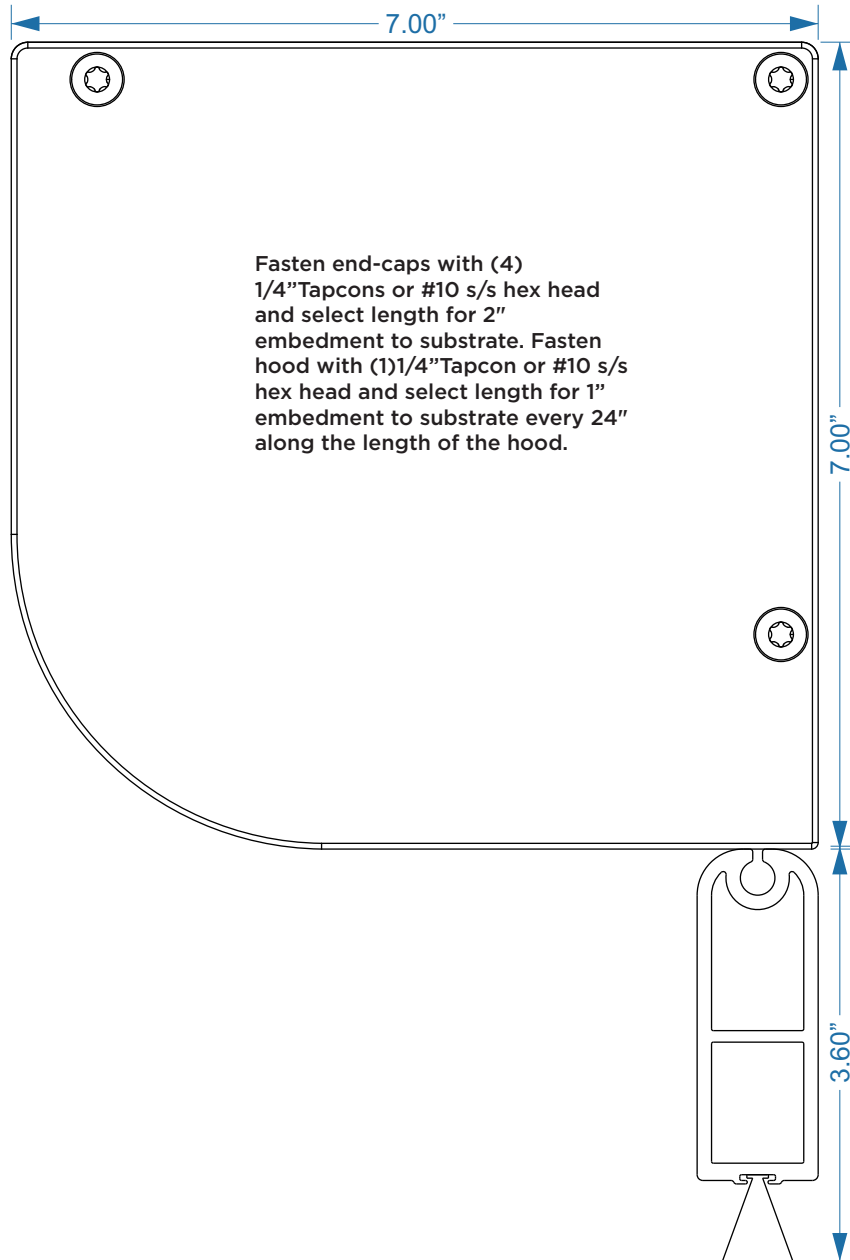

PERGOLA HOOD

AVAILABLE THROUGH
STRUXURE ONLY

SEE CHARTS FOR:

- A) Track Type and Screen Compatibility
- B) Track and Hood Compatibility
- C) Hoods, Motors and Screen Sizes
- D) Standard Extrusion Colors

Please consult **HOW TO MEASURE**
section for details on measuring
screens for production orders.

**MOUNTING HARDWARE NOT
PROVIDED**

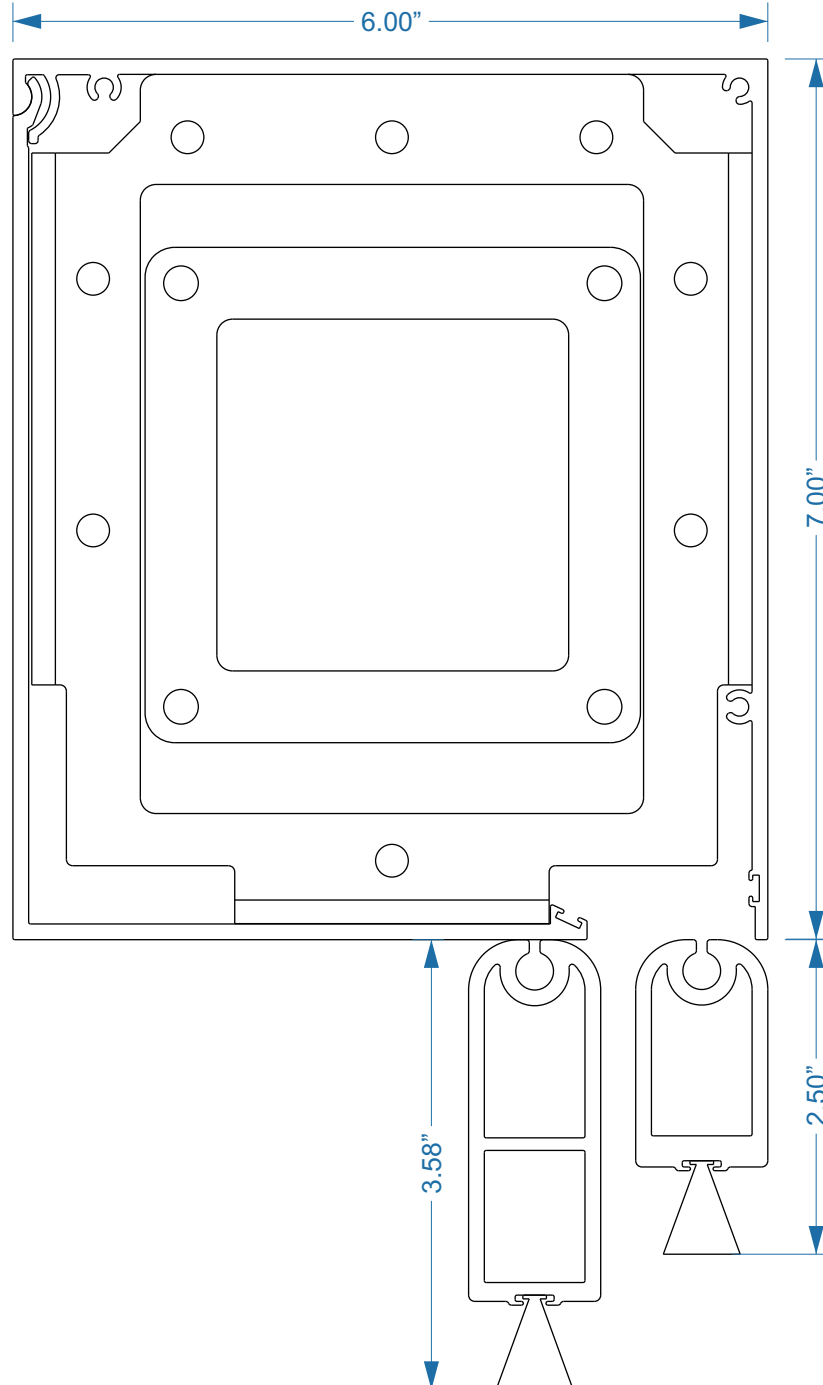

CABLE GUIDED

RECOMMENDED MAX SYSTEM DIMENSIONS*

		Shade	
Max Width		204"	
Max Height		168"	

*Screens ordered outside the recommended max system dimensions require a waiver. The typical issue is wind damage. If you plan to use a shade screen in windy areas consider an end-retention screen like the One-Track on page 1, or using a wind sensor to retract the screen automatically when wind speeds increase over 20 MPH.

SEE CHARTS FOR:

- A) Track Type and Screen Compatibility
- B) Track and Hood Compatibility
- C) Hoods, Motors and Screen Sizes
- D) Standard Extrusion Colors

Please consult HOW TO MEASURE section for details on measuring screens for production orders.

MOUNTING HARDWARE NOT PROVIDED

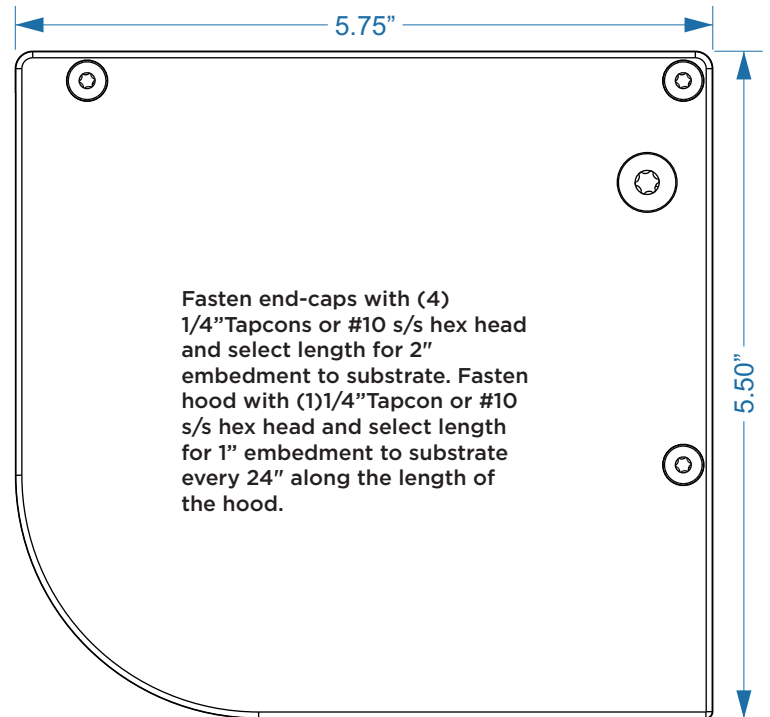
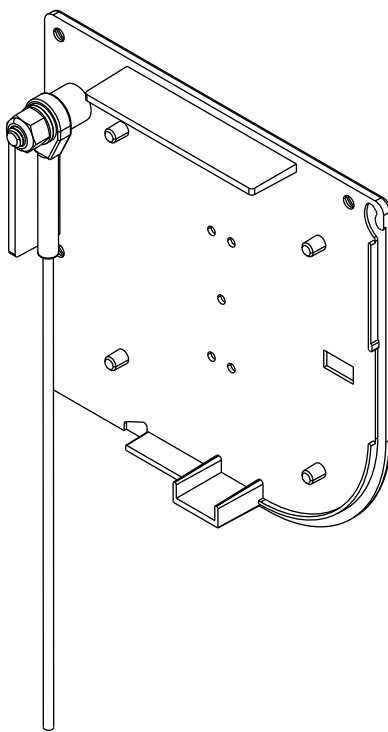

Fasten end-caps with (4) 1/4" Tapcons or #10 s/s hex head and select length for 2" embedment to substrate. Fasten hood with (1) 1/4" Tapcon or #10 s/s hex head and select length for 1" embedment to substrate every 24" along the length of the hood.

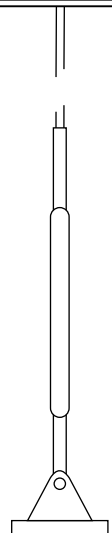
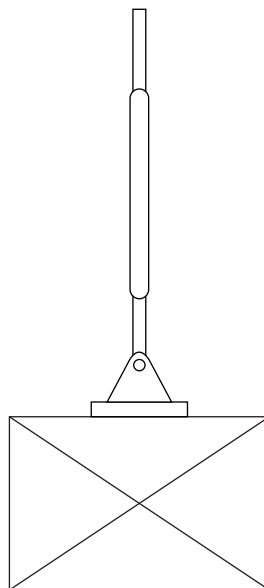
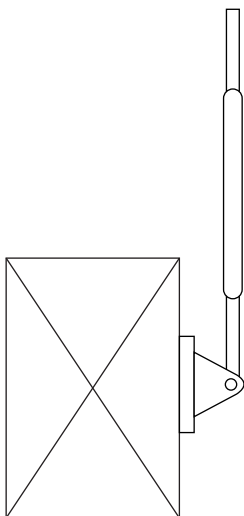

Shown are generic mounting options for the bottom connection. There are many options depending on the installation. Fenetex supplies a 15' cable assembly, and components. Installer must trim and crimp the cable as required. Please contact Fenetex if you have any questions.



1(800) FENETEX www.fenetex.com

A

✓ INDICATES COMPATIBLE CONFIGURATIONS		SCREEN TYPE			
		Insect Screen	Shade Screen	Clear Screen	Maxforce (Hurricane Screen)
TRACKS & WEIGHT BARS	E-Track	✓	✓		
	One-Track	✓	✓	✓	
	Maxforce (Hurricane Track)				✓
	Standard Weight Bar	✓	✓		
	Heavy Weight Bar	OPTIONAL	OPTIONAL	STANDARD	STANDARD

B

✓ INDICATES COMPATIBLE CONFIGURATIONS		HOODS & BRACKETS						
		4.75" Hood	5.5" Hood	7.0" Hood	Perg Hood	6.0" Bracket	7.5" Bracket	8.0" Big Leg Bracket
E-Track		✓	✓	✓	✓			
E-Track jamb Channel		✓	✓	✓	✓			
One-Track		✓	✓	✓	✓	✓	✓	
One-Track Jamb Channel		✓	✓	✓	✓			
One-Track Built-In Channel						✓	✓	
Maxforce (Hurricane Track)			✓	✓	✓	✓	✓	✓
Standard Weight Bar		✓	✓	✓	✓	✓	✓	
Heavy Weight Bar		✓	✓	✓	✓	✓	✓	✓
Cable Guided			✓					

C

✓ INDICATES COMPATIBLE CONFIGURATIONS		OPERATOR TYPE					SCREEN TYPE & MAX DIMENSION W"XH"				
		Fenetex Motor	Somfy Motor	Simu CMO Motor	Gaposa Motor	Gaposa High Speed	Gaposa Solar	Insect Screen	Shade Screen	Clear Screen	Maxforce (Hurricane Screen)
HOODS & BRACKETS	4.75" Hood	✓	✓		✓	✓	✓	197"x108"	197"x108"		
	5.5" Hood (w 4.0 reel)	✓	✓		✓	✓	✓	240"x150"	240"x150"	192"x150"	192"x120"
	7.0" Hood (w 4.0 reel)	✓	✓	✓	✓	✓	✓	240"x207"	240"x207"	192"x192"	192"x168"
	7.0" Hood (w 5.5 reel)	✓	✓	✓	✓			300"x207"	300"x207"	300"x150"	300"x126"
	Pergola Hood (w 4.0 reel)	✓	✓		✓	✓	✓	240"x150"	240"x150"	192"x150"	192"x120"
	6.0" Built-In Bracket (w 4.0 reel)	✓	✓	✓	✓	✓	✓	240"x150"	240"x150"	192"x150"	192"x120"
	7.5" Built-In Bracket (w 4.0 reel)	✓	✓	✓	✓	✓	✓	240"x207"	240"x207"	192"x192"	192"x168"
	7.5" Built-In Bracket (w 5.5 reel)	✓	✓	✓	✓			300"x207"	300"x207"	300"x180"	300"x144"
	8.0" Big Leg Bracket (w 4.0 reel)	✓	✓	✓	✓		✓				192"x240"
	8.0" Big Leg Bracket (w 5.5 reel)	✓	✓	✓	✓						300"x216"

D

✓ INDICATES STANDARD COLORS		EXTRUSION COLORS (INCLUDES END CAPS)							
		Gloss White	Gloss Bronze	TeXture White	TeXture Beige	TeXture Adobe	TeXture Grey	TeXture Bronze	TeXture Black
E-Track				✓				✓	✓
E-Track Jamb Channel				✓				✓	✓
One-Track		✓	✓	✓	✓	✓	✓	✓	✓
One-Track Jamb Channel				✓				✓	✓
One-Track Built-In Channel				✓					✓
Maxforce (Hurricane Track)		✓	✓	✓	✓			✓	✓
4.75" Hood				✓				✓	✓
5.5" Hood		✓	✓	✓	✓	✓	✓	✓	✓
7.0" Hood		✓	✓	✓	✓	✓	✓	✓	✓
Pergola Hood				✓	✓	✓	✓	✓	✓
Standard Weight Bar		✓	✓	✓	✓	✓	✓	✓	✓
Heavy Weight Bar		✓	✓	✓	✓	✓	✓	✓	✓



FENETEX
MOTORIZED SCREENS

1(800) FENETEX www.fenetex.com

HOW TO MEASURE

One-Track (jamb or face mount):

Order by overall system width, the dimension from outside of track to outside of track. Do not include build out.

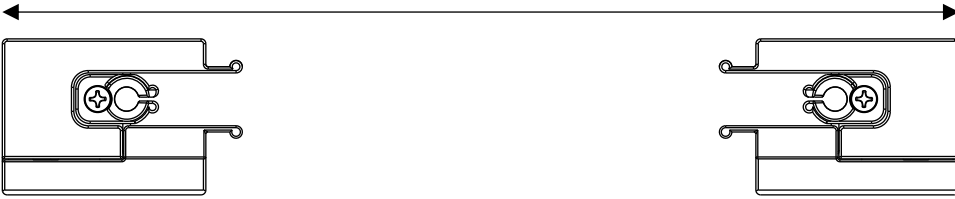

One-Track, using a Built-In channel:

Order by overall system width, the dimension from mounting surface of channel to mounting surface of channel. DO NOT ORDER BY USING THE DIMENSION FROM OUTSIDE OF CHANNEL TO OUTSIDE OF CHANNEL.



Maxforce, E-track (jamb or face mount):

Order by overall system width, the dimension from outside of track to outside of track. Do not include build out.



Dual System using Maxforce, and One-Track (with or without a Built-In channel):

Order EACH SYSTEM USING ITS OWN OVERALL WIDTH as indicated above and shown below.

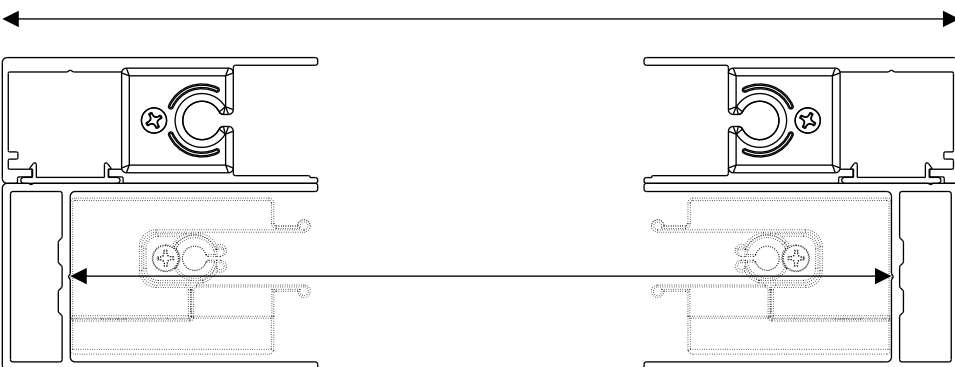

System Height: This is always measured from the top of the hood or built-in bracket to the bottom of the track.

